



## Features

- Intel® Comet Lake Core i CPU
- Anti-bacteria Aluminum Housing
- 23.8" FHD MVA Diagnostic Panel
- Optional Optical Bonding/AG Film
- Optional Full HD Capture Card
- LAN/COM 4KV Isolated Module
- Optional DICOM Part 14 Solution
- Support Video-In with Color Adjustment
- Support DP x 1, HDMI x 1 for Extended Display Output
- Support Windows 11 & fTPM

## Specification

Model	WMP-24M IPOA (STD)	WMP-24M IPOB (ISO)
<b>Main System</b>		
<b>CPU / Chipset</b>	LGA1200 package 10 <sup>th</sup> gen Intel® Core i7/i5/i3/Pentium/Celeron processor (35W max.) Intel® Q470E Chipset (Intel® PCH)	
<b>Graphic</b>	Intel® integrated UHD Graphics by CPU	
<b>RAM</b>	2 x 260-pin SO-DIMM, Dual Channel DDR4 2933 / 2666 / 2400 MHz, up to 64GB	
<b>OS Support</b>	Optional Win 10 IoT Enterprise LTSC 64 bit, Windows 11 IoT Enterprise GAC 64 bit	
<b>Storage</b>	1 x M.2 (M Key, 2280) with NVMe PCIe x4 & SATA3 for SSD, 1 x 2.5" SATA3 HDD/SSD	
<b>Expansion</b>	1 x PCI-E x16(20W Max.), 1x M.2 E key 2230, 1x M.2 (B/M Key, 2242/2260/2280) with PCIe x1	
<b>Display Size</b>	23.8" 16:9	
<b>Display (MVA)</b>	1920 x 1080 (Full HD), 16.7M colors, 178(H) / 178(V), 250 nits (Typ. Center point), CR:3000 : 1 (Typ)	
<b>Touch Screen</b>	Full flat projective capacitive touch panel / Light Transmission: 85% ± 3% / Hardness: 6H pencil, pressure 750g/45° / Life: 100M times	
<b>I.O. Ports</b>	<b>STD</b>	<b>ISO</b>
<b>USB</b>	4 x USB 3.2 gen 2	4 x USB 3.2 gen 2
<b>COM</b>	1 x RS232, 1 x RS232/RS422/RS485	1 x ISO RS232/RS422/RS485
<b>LAN</b>	1 x RJ45 1Gbps Intel® I219LM (AMT/Vpro) 1 x RJ45 2.5Gbps Intel® I225V	1 x RJ45 1Gbps Intel® I219LM (AMT/Vpro) 1 x RJ45 2.5Gbps Intel® I225V , 1 x ISO RJ45 1Gbps
<b>Audio</b>	3.5mm phone jack connector * 2 (Line-out, Mic-In)	
<b>Video output</b>	1 x DP 1.2 / DP++, 1 x HDMI 1.4a	
<b>Video-In</b>	1 x HDMI-in	
<b>Control Hot Key (L to R)</b>	Battery LED Indicator; Power; Menu/Exit; Brightness; Video-In LCD On/Off; Clean Me; Programmable Function	
<b>Mechanical and Environmental</b>		
<b>Cooling</b>	Fanless	
<b>Power Adapter</b>	AC input 100 ~240V / 47 ~ 63 Hz, External power adapter, 180W	
<b>Temperature</b>	Operating Temperature: 0~35°C / Storage Temperature: -20~60°C	
<b>Humidity</b>	Operating & Storage: 10 ~ 90%, non-condensing	
<b>IP Rating</b>	IP65 at front side, Full IP65 w/optional I.O. cover / Touch (standard)/ Glass(customized);	
<b>Housing</b>	Rear: Aluminum Alloy Body / White (Touch)	
<b>Dimensions (Net)</b>	580mm (H) x 350mm (V) x 59mm (T)	
<b>Weights (Net)</b>	11.4 kg (w/o power adapter/battery pack)	
<b>Mounting</b>	VESA 100 x 100	
<b>Certification</b>	FCC (part 18 Class B) / CE (EN 60601-1-2 :2015 ver. 4.0) / VCCI (2016-11, class B) UL(ES60601-1:2012 (V3.1) / cUL (C22.2 No. 60601-1:2014 V3.1) By Project MDR (2017/745) / ISO 14971 / IEC62133 By Project	

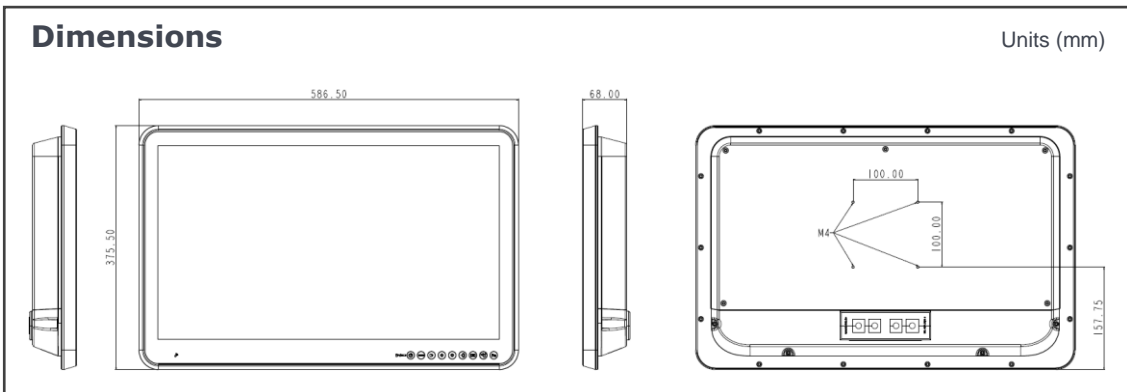

### Major Options

Accessory	<ul style="list-style-type: none"> <li>① Cable clean I.O. cover (w/ 3x sealed grommet; w/ 3-4mm *1, 4-5mm*1, 5-6mm*1, 6-7mm*1 7-8mm*1 grommet)</li> <li>② WMP series stand, VESA 100</li> <li>③ 2M Extension Power DC Cable</li> </ul>
Options	<ul style="list-style-type: none"> <li>① 802.11 ac/a/b/g/n WLAN + Bluetooth module (optional order configuration)</li> <li>② 802.11 ax/a/b/g/n WLAN + Bluetooth module (Wifi-6) (optional order configuration)</li> <li>③ 2.5" SSD module</li> <li>④ M.2 type 2280 module</li> <li>⑤ RFID (13.56MHz)</li> <li>⑥ TPM 2.0 module or fTPM</li> <li>⑦ Full HD capture card or 4K SC710N1 12G SDI capture card</li> <li>⑧ Equipotential terminal pin</li> <li>⑨ AG film</li> <li>⑩ DICOM part 14 compliance (max. error ratio less than 20%, optional order configuration)</li> <li>⑪ Integrated battery x 1 (output 100W max.)</li> <li>⑫ Optical bonding</li> <li>⑬ USB 5,6</li> </ul>
Customization	<ul style="list-style-type: none"> <li>① Tempered glass</li> <li>② Touch with AG coating <ul style="list-style-type: none"> <li>- anti-reflective,</li> <li>- anti-microbial,</li> <li>- anti-glare,</li> <li>- anti-fingerprint</li> </ul> </li> <li>③ Auto focus 5M pixel webcam module</li> </ul>

### Order Information

Item	Configuration
WMP-24M-IP0A-i5	Core i5-10500TE 2.20GHz/DDR4 4G RAM/M.2 128G SSD/ Full flat P.cap touch
WMP-24M-IP0A-i7	Core i7-10700TE 2.0GHz/DDR4 4G RAM/M.2 128G SSD/Full flat P.cap touch
WMP-24M-IP0B-i5	Core i5-10500TE 2.20GHz/DDR4 4G RAM/M.2 128G SSD/Full flat P.cap touch, ISO

### I/O ports (STD)

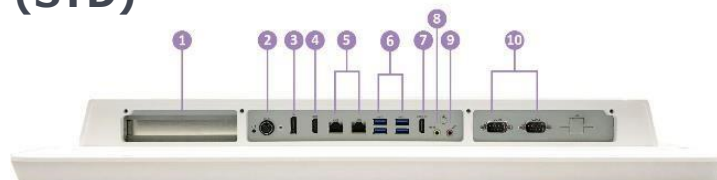

- |                   |               |            |
|-------------------|---------------|------------|
| ① PCI-E Expansion | ⑤ 2 x LAN     | ⑨ Micro-in |
| ② DC-in           | ⑥ 4 x USB 3.0 | ⑩ 2 x COM  |
| ③ DP              | ⑦ Video-in    |            |
| ④ HDMI            | ⑧ Line-out    |            |